



Shanghai Chaori Solar Energy Science & Technology Development Co., Ltd

ADD: Yangwang Economic Area, Fengxian District, Shanghai, China

Tel: +86-21-57470531

Fax: +86-21-57471382

<http://www.super-solar.com>

E-mail: benuming@126.com



* **Wide Range of Applications.**

Grid-connected photovoltaic systems
Between 1 and 100 kWp
Large PV systems and special projects

* **Extended Module Service Life.**

Cells embedded in EVA (ethylene vinyl acetate)
Solar safety glass front
Weather and waterproof foil back

* **Sturdy Frame.**

Fully closed aluminum frame
Frame screwed at end faces

* **Simple Installation.**

Multi-contact plug supplied as standard

* **High Quality Finish.**

Optical, mechanical and electrical module
Testing during and post-production
Automated production line ensures consistently
High level of product quality

* **Warranties and Certificates.**

25 year warranty on 80% of the minimum output
5 year product warranty
IEC 61215, TÜV Safety Class II, CE, ISO



*** Technical Data 175W:**

Max.output(Pmax)as per STC*	175W±3%
MPP voltage(Vmpp)	35.0V
MPP current(Impp)	5.00A
No-load voltage(Voc)	43.0V
Short-circuit current(Isc)	5.42A
Temperature coefficient(Pmpp)	-0.38%/
Temperature coefficient(Voc)	-0.146V/
Temperature coefficient(Isc)	+4.6mA/
Maximum system voltage	1000V
Cells	72 monocrystalline

Cell dimensions	125×125mm
Module dimensions(L×W×H)	1580×808×46mm
Weight	15 kg

* Standard Test Conditions, which are defined as follows: radiations output of 1000w/m² (max.insolation) at a spectral density of AM 1.5 (ASTM E892), cell temperature of 25 .

*** Electric Characteristics**

Current, Power & Voltage Data (Standard Test Condition)

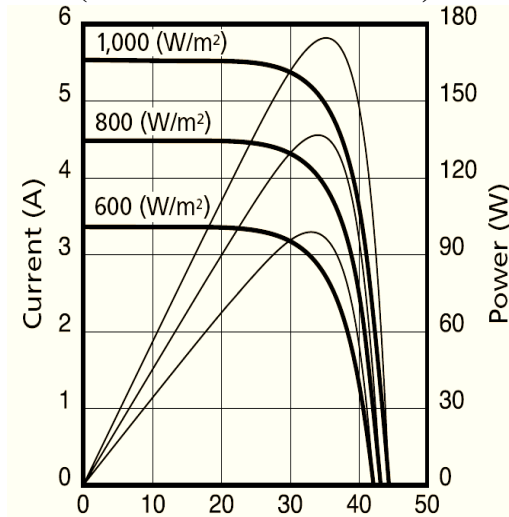

Voc, Isc & Irradiance Data (Standard Test Condition)

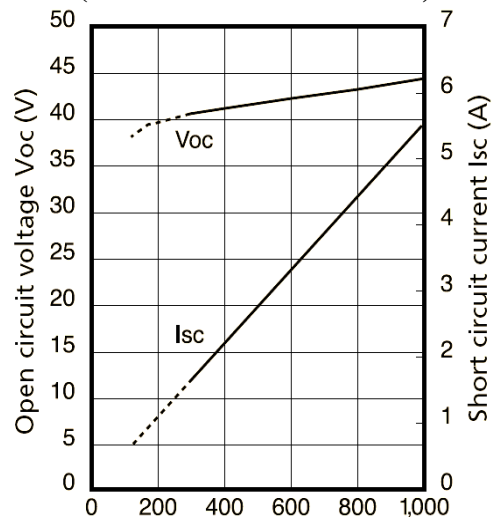

*** Dimensions**

Front Side

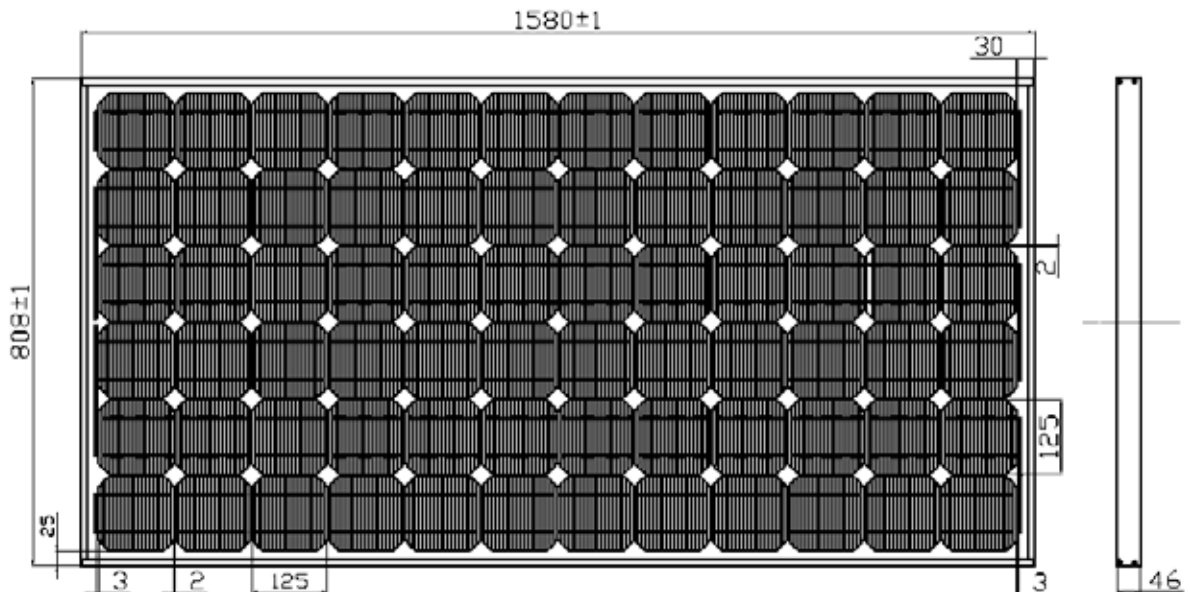

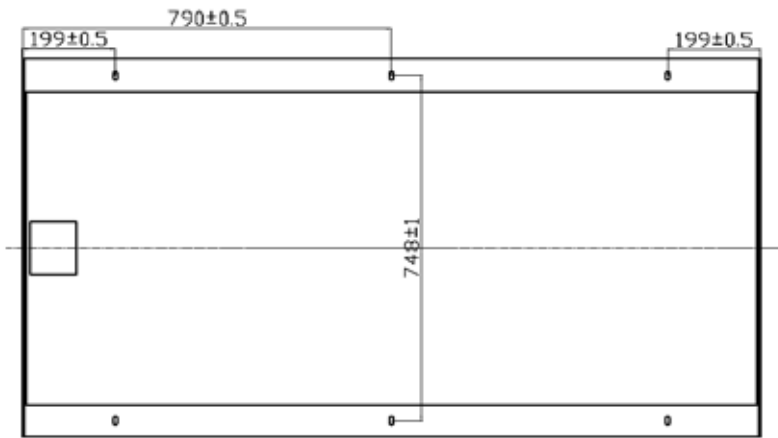
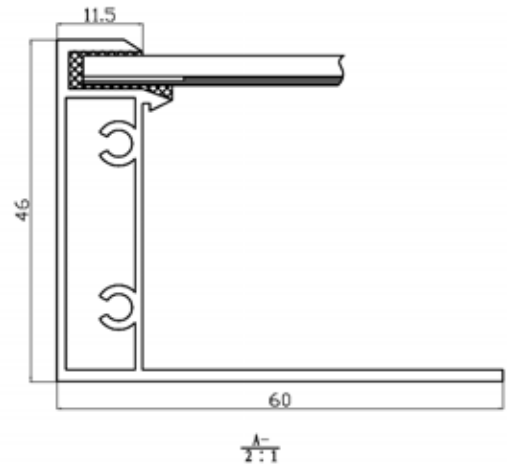
Back Side**Cross Section**

* Installation Instructions

1. Solar module can build on horizontal or inclination plane, we use stainless steel screw fixup on the bracket which we already fixup. Waterproof also the important point, if possible please put the junction box on top of battery parts, we use the threading pipe as down-lead , if don't use the threading pipe, you should put the down-lead at the place without water.
2. You should make sure the battery parts is earth, it must be let the professional do the job of earth, let the professional make sure has no creepage and lightning protection, if possible make sure between parts and parts has 200mm(distance) , make sure it has good ventilation.
3. Solar module exterior should be uprightness and face sun, reduce loss from exterior sunshine and raise export power. That's why the solar module has some angle, how much degree we need to use, it's depend on sunlight and special System design.
4. If you want solar module has best output every day in one year, we suggest the obliquity equal to latitude of you live city. If you want solar module has best output power every day in winter ,we suggest the obliquity equal to latitude of you live city plus 10 degree. If you want solar module has appropriate output every day in the four seasons , we suggest the obliquity equal to latitude of you live city minus 10 degree.
5. When you want to do one kind of upside ,only one important thing is you need to make sure , around solar module has no shadow of tree, shadow of building, shadow of cable, because the shadow will overcast the solar module which will make the solar module out of gear.

* Maintanance Keypoints

1. Make sure the module exterior has no dust and dirt, if possible clear the parts sometimes .
2. Make sure don't use any Hard thing to rub the face of modules.
3. Inspect any bad mark on solar module: inspect those may broken cable, inspect those may corroded module (make sure creepage or not)
4. Inspect is that the all connect be ruggedization, is that the screw of bracket be ruggedization, is that the connection be ruggedization, the regulate and the fasten be needed.